

- Cash     Insurance  
 Grant     Other

# PER4MAX SHOCKWAVE

Rep.: \_\_\_\_\_  
Event: \_\_\_\_\_

Name: \_\_\_\_\_  
Address: \_\_\_\_\_  
City: \_\_\_\_\_  
State: \_\_\_\_\_ Zip: \_\_\_\_\_  
Email: \_\_\_\_\_

Date: \_\_\_\_\_ SSN#: XXX - XX - \_\_\_\_\_  
Age: \_\_\_\_\_ Weight (lbs.): \_\_\_\_\_ Height: \_\_\_\_\_"  
Disability: \_\_\_\_\_  
Tel #: ( ) \_\_\_\_\_ - \_\_\_\_\_ (Home or Work)  
Other Info: \_\_\_\_\_

## FRAME SPECIFICATION

### Model

SHOCKWAVE (K0005) ..... Retail: \$ 3649

#### 1) Seat Width (E2201- WIDTH 20-24")

- 12"    13"    14"    15"    16"    17"    18"  
 Other \_\_\_\_\_ (Add \$250)

#### 2) Seat Depth (E2203- DEPTH 20-22")

- 12"    13"    14"    15"    16"    17"    18"  
 Other \_\_\_\_\_

#### 3) Total Length \_\_\_\_\_"

#### 4) Rear Seat Height

- 16"    17"    18"    19"    20"    21"

#### 5) Front Seat Height

- 16"    17"    18"    19"    20"    21"

#### 6) Backrest Height

- 10"    12"    14"    16"    Other: \_\_\_\_\_"

- Back Height Adj. : From \_\_\_\_\_" to \_\_\_\_\_" ..... \$ 80

#### 7) Back Angle

- 0°    3°    5°    Other: \_\_\_\_\_°

#### 8) Foot Width

- 8"    9"    10"    11"    Other: \_\_\_\_\_"

#### 9) Lower Leg Length \_\_\_\_\_" (16", 17", etc.)

#### 10) Backrest To Center Axle

- 0"    1"    2"    3"    Other: \_\_\_\_\_"

#### 11) Center Axle To Caster Housing

- 14"    15"    16"    17"    Other: \_\_\_\_\_"

#### 12) Caster Housing To Front Foot Plate

- 3"    4"    5"    6"    Other: \_\_\_\_\_"

#### 13) Center of Caster to Caster

- 12"    14"    16"    18"    Other: \_\_\_\_\_"

#### 14) Side Wheel Clearance

- 1/2"    1"    1 1/2"    2"

#### 15) Camber Angle

- 0°    3°    6°    Other: \_\_\_\_\_°

# Notes:

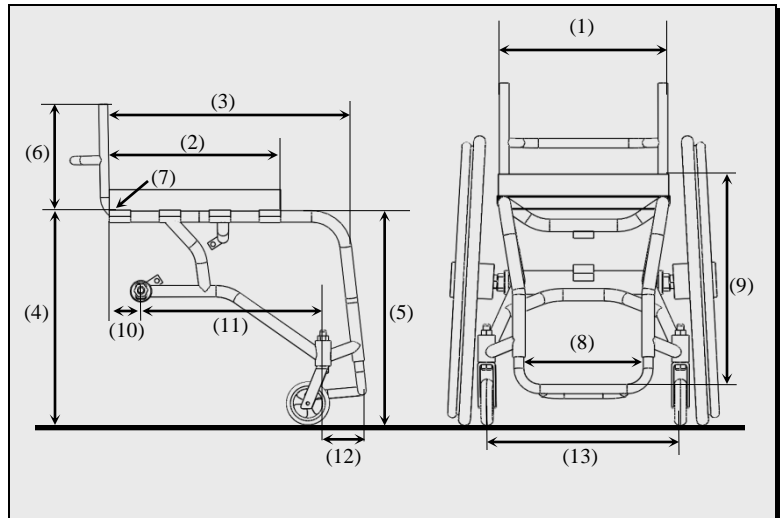

\*Effective: March 2015

Pricing and specifications are subject to change without notice

Customer Service:  
Telephone: 972-641-6773  
Fax: 972-782-9011

PER4MAX MEDICAL  
www.per4max.com  
Page 1 of 2

1000 Post & Paddock Ste. 310  
Grand Prairie, TX 75050

# PER4MAX SHOCKWAVE

## FRAME COLORS

- Sky White     Bonded Silver     Dormant Violet     Ruby Red     Glossy Black     Matte Black     Safety Yellow  
 Candy Blue     Candy Red     Sparkle Green     Safety Orange     Polish (Brushed)  
 Accessory Colors Standard Glossy Black     Accessory Color Option \_\_\_\_\_ (one color additional: \$350)  
 Other: \_\_\_\_\_ \$TBD     Backrest     Footrest     Camber Bar     Side Guards

## WHEELCHAIR OPTIONS

### BACK REST

- Rigid ..... NC  
 Folding ..... \$ 280

### PUSH HANDLES

- Removable ..... \$ 250  
 Retractable ..... \$ 250

### SIDE GUARDS (K0108)

- Aluminum (Folding backrest requires removable or integrated) \$ 140  
      Removable Extra ..... \$ 90  
 Special Size Aluminum (H\_\_\_\_\_x L\_\_\_\_\_). ..... \$230  
 Removable Plastic ..... \$ 225

### WHEEL LOCKS (E2206)

- Push Locks ..... NC  
 Scissors Locks ..... \$ 220  
      Top    or     Bottom ..... (install)  
 D's Locks ..... \$650

### CASTERS

- 3" (72mm) Micro ..... NC  
 4x1" Plastic ..... \$55  
 5x1" Plastic ..... \$65  
 4x1" Aluminum ..... \$ 95  
 5x1" Aluminum ..... \$ 100  
 Frog Legs (E1015)..... \$ 329  
 Other \_\_\_\_\_ \$TBD

### MISCELLANEOUS

- Swing Away Armrest (E0994) ..... \$ 350  
 Anti-Tip Bars (E0971) ..... \$ 225  
 Special Cushion (Roho, Stimulite Etc.) (E2603) ..... \$TBD  
 Foam Impact Guards ..... \$ 75  
 Nylon Pouch ..... \$ 60  
 Plastic Foot Plate (K0042) ..... \$ 80  
 Tension Backrest Upholstery (E2611)..... \$300  
 Seat Belt (E0978)..... \$125  
 Other \_\_\_\_\_ \$TBD

## WHEELS & TIRES

### WHEELS

- Rear Wheels .....\$300  
      24"     25"     26"     27"  
 Spinergy Wheels .....\$695  
      24"     25"     26"     27"  
      Black     White     Blue     Red     Yellow  
      Spinergy Light Extreme (LX).....add \$200  
          Green     Orange     Pink

### HAND RIMS SYLE

- Hard Anodized 6 tab ..... **Std.**  
      Mounting Close to Tire  
 Vinyl Coated ..... \$90  
 Other \_\_\_\_\_ \$TBD

### TIRES

- High Pressure Tires (E2211, E2212)..... **Std.**  
 Schwalbe Marathon Plus ..... \$150  
 All Terrain Tires ..... \$100  
 Solid Airless Tires (E2218) ..... \$110  
 Other \_\_\_\_\_ \$TBD

Notes:

\*Effective: March 2015  
Pricing and specifications are subject to change without notice

Customer Service:  
Telephone: 972-641-6773  
Fax: 972-782-9011

**PER4MAX MEDICAL**  
www.per4max.com  
Page 2 of 2

1000 Post & Paddock Ste. 310  
Grand Prairie, TX 75050